

Design of Solar of Cell and PLN Using Automatic Transfer Switch (ATS) for Minimarket Loads in Sorek Satu Area

Antonius Rajagukguk*
Engineering Faculty
Universitas Riau
Pekanbaru, Riau, Indonesia
antoniusrajagukguk@gmail.com

Kurniawan Trisna Rinaldi
Engineering Faculty
Universitas Riau
Pekanbaru, Riau, Indonesia
Kurniawan.trisna3895@student.unri.ac.id

*Corresponding author: Antonius Rajagukguk,
antoniusrajagukguk@gmail.com

Abstract— Solar energy is an unlimited amount of renewable energy and can be used as a power plant that can be used to meet the electrical energy needs of an area, especially areas affected by the equator. Utilization of solar energy still cannot be applied optimally in some areas. In this study, the use of solar energy is used as the main source of electricity to be used by a minimarket. The use of this solar energy generator is equipped with a backup generator, namely the PLN generator, the selection is intended so that the utilization of solar energy can be maximized. The use of these two power plants in a hybrid manner requires a device so that the transfer from one generator to another can be done automatically. In this study, the tool used is the automatic transfer switch (ATS). The work parameters carried out by ATS are based on reading the battery voltage value. If the battery voltage is 10.8V – 13.2V, the solar energy generator will work to supply the minimarket load, and if the battery voltage does not reach 10.8V, the PLN generator will work to supply the minimarket load.

Keywords—Automatic Transfer Switch (ATS), Battery Voltage, Solar Energy.

I. INTRODUCTION

Solar panels are one of the alternatives that are widely used because sunlight is a source of regenerative energy and is the only almost unlimited energy source in nature. PLN as a provider of electrical energy or commonly referred to as the main power supply cannot be provided continuously or continuously whether it occurs due to disturbances or there are other obstacles that cause PLN to not be able to guarantee the availability of electrical energy continuously. The availability of electrical energy is one of the important factors during very rapid technological developments. However, because the electrical system can be said to be very complex, starting from the generation center to the consumers, it is very likely that there will be disturbances that can cause power flow to consumers to be cut off.

ATS (Automatic Transfer Switch) is used as a tool to control the switch from the main supply to the backup supply needed by an equipment when the main supply goes out. The main supply referred to in the study is electrical energy and a backup supply in the form of solar energy. Electrical energy is the main requirement to operate electronic devices. To overcome the disconnection of electrical power services, an emergency power plant (emergency) such as solar cells is needed as a back-up supply or other renewable energy sources when the supply from PLN is not available. As a control when the solar cell takes over the electricity supply to the load or vice versa, a control system is needed that can work automatically to run the solar cell when there is a blackout from the solar panel.

This study aims to design and analyze a solar cell generator that is used to load a minimarket in the Sorek Satu area. This is because there are frequent interruptions to the power source in the PLN supply, such as unstable voltage even to the point of blackouts at the Minimarket. The solar cell generator design that will be designed involves a backup power source, namely the PLN supply. The design of this solar cell generator is also equipped with the use of Automatic Transfer Switch (ATS) which aims to facilitate the transfer of electricity sources in an automatic way. When the main power source is interrupted causing a blackout, the ATS will work by moving the supply position to the backup supply.

II. METHODOLOGY

A. Diagram of Block

In this study, the design of the solar cell generator consists of components such as a charger controller, battery, and inverter which are used to generate electricity to drive the minimarket load.

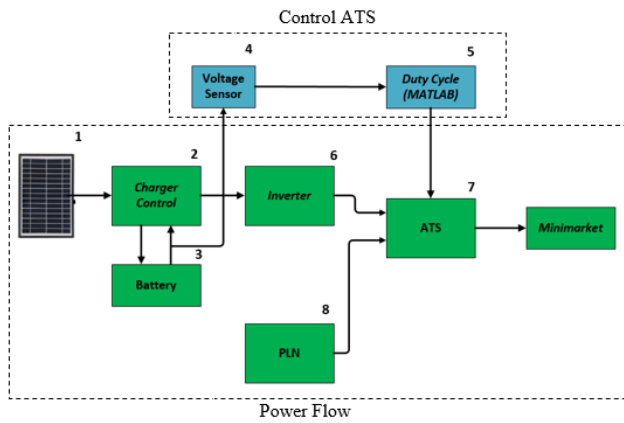

Fig.1. Block Diagram

Then the ATS (duty cycle) controller will see the results of measuring the voltage value from the main source first, the measured voltage value is adjusted to the tolerance value of the voltage value, which is $\pm 10\%$ of the 12 Volt reference voltage or 10.8 Volt or 13.2 Volt. From the battery voltage which was originally a direct voltage (DC) then it will be converted into an alternating electric voltage (AC) using an inverter. When the voltage is at nominal 10.8 volts, the ATS will work by moving the load that initially gets supply from the Solar Cell generator power source into a load that gets supply from the PLN power source.

B. Load Capacity

The load to be calculated is the burden of a minimarket located in the Sorek Satu area where ATS equipment will be installed with a power source coming from PLN and a power source originating from Solar Cell power with the following formula:

Power Usage = Number of units power x power unit

Type Lamps: T8 LED

Lamps: 66 unit

Power: 18 Watt

Power Usage = 66×18

Power Usage = 1188 Watt

To calculate kWh per day can use the following formula:

Total Energy Watt Hours = Power Usage x Time Usage

Great Power Usage: 1,188 Watt

Time Usage: 16 Hours

Total Energy Watt Hours = 1188×16

Total Energy Watt Hours = 19 kWh

The calculation above applies to all types of loads in minimarkets in the Sorek Satu area.

Lamp	= 20688 Wh
Refrigerator	= 59200 Wh
AC	= 46080 Wh
Freezer	= 20352 Wh
Etc	= 160 Wh
Wtotal	= 146552 Wh
	= 146,552 kWh

TABLE 1. LOAD CAPACITY

No	Load Type	Amount Of Usage (Units)	Great Power On Load (W)	Long Time Of Use (Hour)	Total Energy (Wh)
1	Lamp T8 LED	66	18	16	19008
	Lamp Philips LED	7	15	16	1680
2	Refrigerator type GEA	5	420	24	50400
	Refrigerator type Coca Cola	1	370	24	8800
3	Air Conditioning PANASONIC	2	1440	8	23040
	Air Conditioning PANASONIC	2	1440	8	23040
4	Freezer type Maspion	1	138	24	3312
	Freezer type GEA	2	355	24	17040
5	Etc	0	10	16	160
		86	4206		146552

C. Solar Panel

The panel used in this study uses a single-type solar panel with a power of 500 Watt and the recommended usage time is 5 hours per day. The selection of panels with 500 Watt of power is due to the greater the size and peak power of the panels, the greater the electrical power generated.

$$\begin{aligned} \text{Number of panels} &= \frac{W_{\text{total}}}{p \times t} \\ &= \frac{146552}{500 \times 5} \\ &= 58,6 \text{ or } 60 \text{ panels} \end{aligned}$$

With the number of solar panels used as many as 60 units, this study uses the layout of the solar panel arrangement by utilizing the parallel connection circuit model.

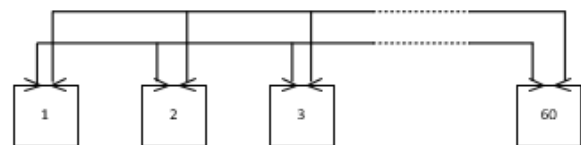

Fig. 2. Solar Cell Connection

In the arrangement of the solar panel layout using a parallel connection, the voltage value to be generated by the solar panel will remain the same as the working voltage value, but the current value will continue to increase.

D. Solar Charge Controller

To determine which solar charger controller to use, the first thing to do is to know in advance the output of the solar panels used. In addition, the solar charger controller must also pay attention to the size of the minimarket's power capacity needs. Based on the above specifications, it is known that the input from this rover type SCC is 48V-150V with the output voltage generated by the solar panel is 53V.

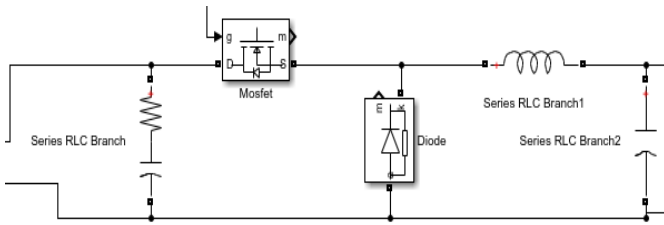

Fig. 3. Design SCC

One unit of this type of SCC can accommodate the current generated by the solar panel of 100A, while the current generated by the solar panel in this study is 540A with a total of 60 panels. So that the use of SCC in this study uses six units of SCC arranged in parallel so that the current that can be accommodated by SCC is 600A. Each SCC unit will accommodate the current generated by 10 units of solar panels. Based on this explanation, this type of SCC can work based on the voltage generated by the solar panel.

E. Battery

In addition to knowing the battery specifications, here are also the characteristics of the battery used. Based on the characteristics of the picture above, there are several comparisons involving the capacity of the battery to be used. The battery capacity used in this study is a battery with a capacity of 12 Volt, 200 Ah.

$$\text{Battery Capacity} = \frac{W_{\text{total}} \times 2}{V}$$

$$= \frac{146552 \times 2}{12}$$

$$= 24452,3 \text{ Ah}$$

$$\text{Number Of Batteries} = \frac{24452,3}{200}$$

$$= 122,26 \text{ or } 124 \text{ units}$$

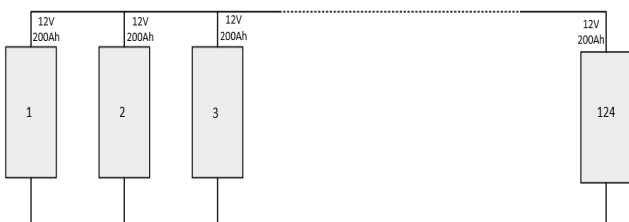

Fig. 4. Battery Connection

F. Inverter

For the inverter itself, to find out the amount of the required inverter value, first find the value of the total power used so that we can choose the suitable inverter specifications. The inverter size used is at least equal to the total power used simultaneously. To find out the value of the voltage generated by the inverter in this study, it can be calculated using the following formula.

$$V_{\text{rms}} = V_{\text{eff}} = 380 \text{ V}$$

$$V_p = V_{\text{rms}} \times \sqrt{2}$$

$$= 380 \times \sqrt{2}$$

$$= 537,4 \text{ V}$$

$$V_{p-p} = V_p \times 2$$

$$= 537,4 \times 2$$

$$= 1074,8 \text{ V}$$

G. Automatic Transfer Switch (ATS)

In this study using three conditions that will be used in the relay module, the first relay condition is a relay for a working solar cell generator, the second relay condition is a working PLN supply relay, and the third relay condition is a relay for the battery charging process at the same time. suggested by solar panels to work to convert sunlight into electrical energy. The relay will work when the ATS controller has given a condition. The first condition is when the voltage value is within the battery voltage tolerance value (10.8 volts - 13.2 volts) then the relay that will work is relay 1 (solar cell relay), and the second condition when the voltage value is outside the battery voltage tolerance value (< 10.8 volts) then the relay that will work is relay 2 (PLN relay)

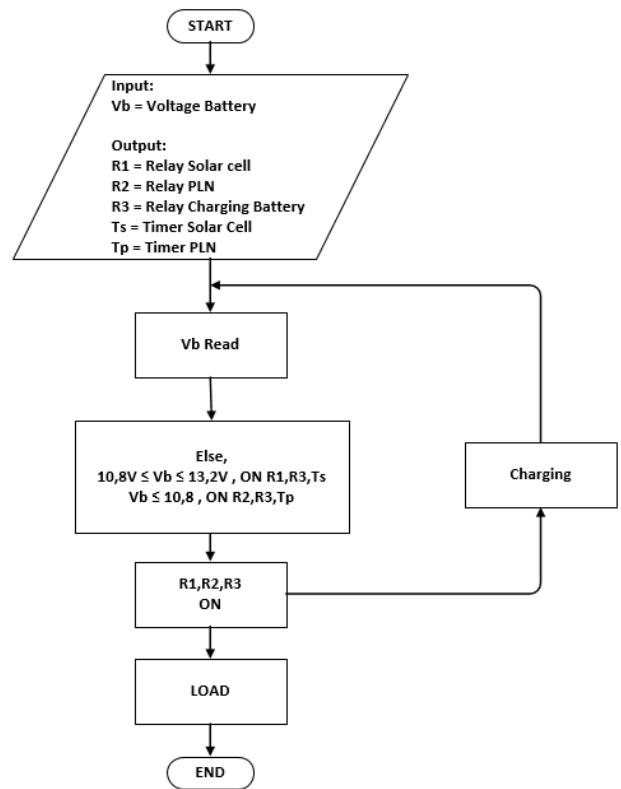

Fig. 5. Flowchart ATS

Take a reading of the battery output voltage. If the battery voltage is within the tolerance value of the battery voltage (10.8V & 13.2V), then the solar cell timer is in the ON condition after that R1 (solar cell relay) is in ON condition and the load will get supply from the solar generator cells. When the load gets a supply from the solar cell at 10 AM, then R3 (battery charging relay) becomes ON and will carry out the charging process. R3 becomes OFF when the battery

capacity has been met or the time has shown 3PM. If the battery voltage is outside the tolerance value of the battery voltage ($V_b \leq 10.8 \text{ V}$), then R2 (PLN relay) becomes ON and the load will get a supply from the PLN source. When the load gets a supply from PLN at 10AM, then R3 (battery charging relay) becomes ON and will carry out the charging process. R3 will be OFF when the battery capacity has been met or the time has shown 3PM. When PLN is the source to drive the load, the battery charging process will occur at 10AM – 3PM, and when the battery voltage reaches a voltage of 13.2V, the process will repeat itself.

H. Testing Automatic Transfer Switch (ATS) With The Programs

```

Program Algorithm of ATS
function [Dp,Dn] = DutyRatio(Va, Vp, Vn)
Dmax=13.2;
Delay=12.9;
Dmin=10.8;
Dinit=-10;
if Vp>Dmax
    Dp=1;
    Dn=0;
    delay=20;
elseif Vp<Dmin
    Dp=0;
    Dn=1;
    delay=20;
elseif Vp>Delay
    Dp=0;
    Dn=0;
    delay=20;
elseif Vn<Delay
    Dp=0;
    Dn=0;
    delay=20;
elseif Va>Dinit
    Dp=0;
    Dn=1;
elseif Va<Dinit
    Dp=1;
    Dn=0;
end

```

The test in the first condition is carried out when the battery voltage value is outside the voltage tolerance value limit, which is $\pm 10\%$ of the 12V working voltage (10.8V-13.2V). The test in the second condition is carried out when the battery voltage value is at the limit of the voltage tolerance value, which is $\pm 10\%$ of the 12V working voltage ($<10.8\text{V}$).

III. RESULT AND DISCUSSION

The solar cell generator and PLN supply with the use of (ATS) Automatic Transfer Switch are designed using MATLAB (Matrix Laboratory) software. The control used in this research design uses the MATLAB function component found in the MATLAB software, which functions to make the use of ATS easier to control. The first test is when the battery voltage value is still within the voltage tolerance value, which is $\pm 10\%$ of the 12V working voltage. This means that when the battery voltage is 10.8V - 13.2V, the power source that will work to supply the load is a power source from the solar cell. The second test is when the battery voltage value is outside the voltage tolerance value limit, which is $\pm 10\%$ of

the 12V working voltage. This means that when the battery voltage is 10.8V, the power source that will work to supply the load is a power source from PLN.

A. Simulation Design Results

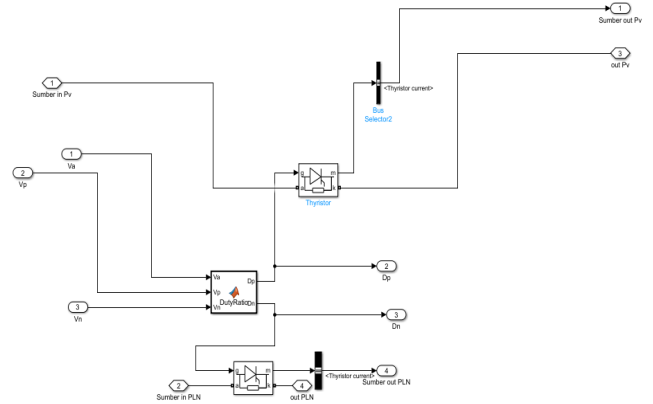

Fig. 6. Design ATS

B. Solar Panel Results

I-V characteristic curve in this study can be seen the influence of the irradiance value based on the solar panels used in this study will be directly proportional to the value of the current, voltage, and power generated. This means that the greater the value of irradiance generated by the solar panel, the greater the value of current, voltage and power that will be generated. The output voltage generated by the solar panel appears to be stable for a certain time. The decrease and increase in voltage occur due to the influence of the irradiance value obtained by the solar panel which decreases and increases.

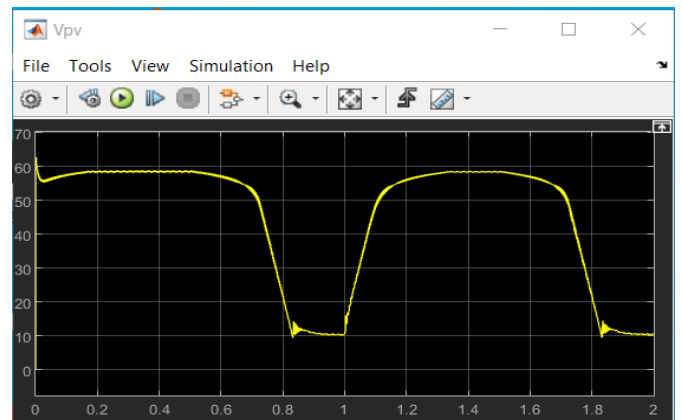

Fig. 7. Result of Solar Cell Design

C. Solar Charge Controller Results

In this study, the voltage value generated by the solar cell power source will be reduced using a converter contained in the solar charge controller circuit with the aim that the voltage generated from the solar cell power source can be adjusted to the specifications of the battery. In this research, the solar

charger controller uses a buck converter. This means that the output voltage value generated when using a buck converter will be lower than the output voltage value generated by the solar panel. When there is no change in the irradiance value on the solar panel, the duty cycle ratio will also not change. If the irradiance value is decreased, the duty cycle ratio will decrease, and if the irradiance value is increased, the duty cycle ratio will increase. This proves that the effect of the irradiance value will be directly proportional to the changes that occur in the duty cycle ratio.

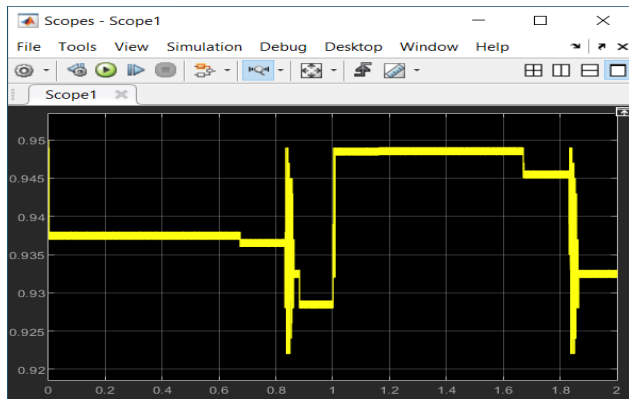

Fig. 8. Result of Duty Cycle

The battery in this study gets a supply from a solar cell power source, where the voltage generated by the solar cell power source must be lowered first using a buck converter circuit so that it can be adjusted to the specifications of the battery used. The results of the battery circuit made in this study include the percentage of the battery, the current generated by the battery, and the voltage generated by the battery. The output voltage produced by this battery will be the reference value as an Automatic Transfer Switch (ATS) controller to move the power source that will provide supply to the load.

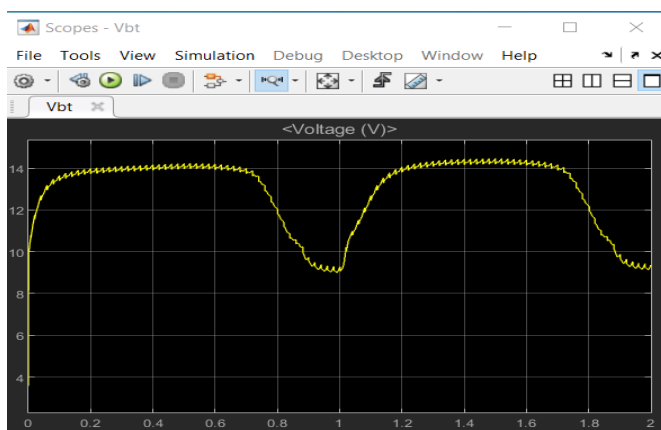

Fig. 9. Result of Battery Design

The initial process in the design of this research is the battery charging process that occurs when the solar panel gets sunlight. The value of the battery voltage will increase and decrease according to the output voltage of the SCC. This means that the value of the battery voltage will be directly proportional to the output voltage of the SCC. This means that when the voltage generated by the SCC increases, the battery voltage will also increase and vice versa. The increase

and decrease in battery voltage is also influenced by the voltage generated by the solar panel and is influenced by the irradiance value obtained by the solar panel.

D. Inverter Results

Based on the results of the inverter circuit design using MATLAB software in this study, the change in the DC voltage from the battery to AC voltage uses four Mosfet components that work alternately so that the output voltage from the battery is initially DC voltage and then converted into AC voltage. After the resulting voltage is converted to AC voltage, the resulting voltage will be increased using a transformer. The transformer in this study is designed with the principle of a step-up transformer. The voltage is increased from 12V to 380V.

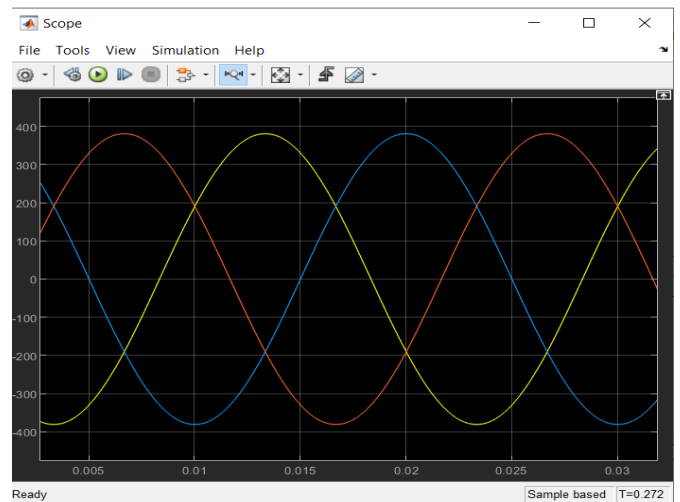

Fig. 10. Result of Inverter Design

The results of the inverter voltage show that the voltage generated by the inverter has become an AC voltage as evidenced by the output of the inverter in the form of sinusoidal waves. When the inverter voltage has become AC voltage, then at that time the solar cell generator can already work to drive the minimarket load used in this study.

E. Automatic Transfer Switch Results

ATS will work based on reading the output value on the voltage generated by the battery. After the output voltage value is read by the voltage sensor, the ATS controller (MATLAB function) will provide conditions to be forwarded to the relay. MATLAB function will provide two conditions to command and select the relay that will work. The condition regulated in the MATLAB function is when the voltage value issued by the battery is between the voltage value of 10.8V to 13.2V, and the other condition is when the voltage value issued by the battery is <10.8V. Based on these conditions, the selection of the relay that will work will get the command given by the MATLAB function.

It can be seen that the first condition given by the MATLAB function is that the solar cell generator is in condition (1) which means the solar cell generator will work to provide supply to the minimarket load and when the MATLAB function provides condition (0) then the solar cell generator will perform the charging process on the battery

and MATLAB function will provide the second condition, namely the PLN supply that will work. When the charging process is complete, the MATLAB function will instruct the solar panels to work again by providing supply to the minimarket load.

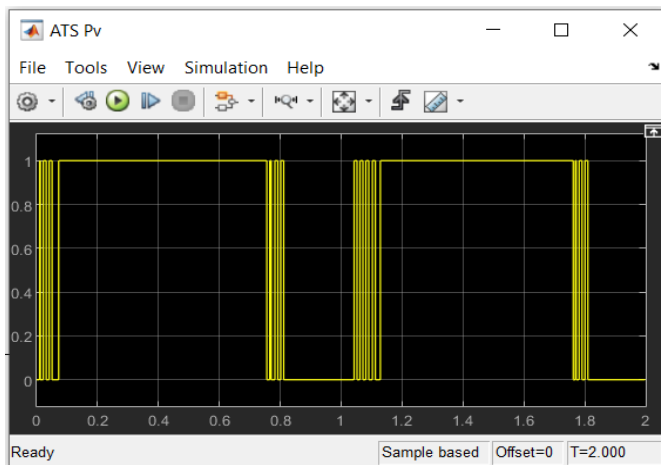

Fig. 11. Result of ATS Design

In the design of solar cell generators and PLN supply with the use of Automatic Transfer Switch (ATS) in this study, we will compare the results of the selection of generator sources that will provide supply to minimarket loads. In another study with the title of analyzing ATS control, a test was carried out which aims to test the selection of a priority power source that will provide supply to the minimarket load. Based on testing the selection of electrical resources that are a priority to provide supply to the load using ATS, it is in accordance with the working principle of ATS control that has been studied by other researchers. With the results it has been said that the working principle of ATS control has been said to be in accordance with the objectives and has been successful.

IV. CONCLUSION

The conclusions obtained based on the results of the design with simulations in the study are as follows:

- The results of the design of a solar cell generator and a PLN supply using an automatic transfer switch (ATS) for minimarket loads after a simulation using MATLAB software has proven to work well.
- Based on the test of variations in the irradiance value at 1000w/m, the voltage generated by the solar panel is 53V and when the irradiance value is 100w/m, the voltage generated by the solar panel is 18V. This means that the greater the irradiance value, the greater the voltage generated, and vice versa, the smaller the irradiance value, the smaller the resulting voltage.
- The 53V voltage generated by the solar panel will be reduced using a buck converter to 12V or according to the specifications of the battery used.
- When the solar panel voltage is 53V, the voltage generated by SCC is 13.40V and when the solar panel voltage is 18V, the voltage generated by SCC is 11V. This means that the greater the solar panel voltage, the greater the SCC voltage, and vice versa, the smaller the solar panel voltage, the smaller the SCC voltage.

- When the SCC voltage is 13.4V, the voltage generated by the battery is 13.2V and when the solar panel voltage is 11V, the voltage generated by the SCC is 10.8V. This means that the greater the SCC voltage, the greater the battery voltage, and vice versa, the smaller the SCC voltage, the smaller the battery voltage.

REFERENCES

- Afriani, N. & Putra, N.M.D. Characterization of organic solar cell prototype based on shallot extract fabricated by method spincoating *Spincoating. Unnes Physics Journal*, 4(1), 18-25, 2015.
- Almadani, I. F., Haryudo, S. I., & Kartini, U. T. Design and build an automatic transfer switch system between PLN electricity and small scale PLTS for egg based incubators *Internet Of Things. Jurnal Teknik Elektro*, 10(3), 565-575, 2021.
- Aritonang, M, Rajagukguk, A. 10 KWp capacity PV generator power optimization based on P&O algorithm and boost converter using by MATLAB. *JOM FTEKNIK*, 6 (2), 1-11, 2019.
- Damayanti, E., & Iyas, M. Design and build a hybrid ATS panel system prototype between wind turbine and solar cell with PLN grid for home electrical energy with power 456w. *TEDC*, 12(1), 23-30, 2018.
- Dewangga D. D., Suhanto., Moonlight L. S. Design and Build Prototype Control and Monitoring Automatic Transfer Switch (ATS) on PLN and Solar Cells Based on Programmable Logic Controller (PLC). Proceedings of the National Seminar "Aviation Technology Innovation (Snitp)". Airport Electrical Engineering Department, Aviation Engineering Faculty, Aviation Polytechnic Surabaya. 1-7, 2019.
- Dewi, A. E. "Optimizing the Solar Cell Panel Circuit by Using a pb-acid Battery as a Solar Energy Storage System". Thesis of the Department of Physics, Faculty of Mathematics and Natural Sciences, Sebelas Maret State University, 2017.
- Dipociala. "Design of ATs (Automatic Transfer Switch) on Solar Cell-Based Inverter at Lkc Clinic, Dompot Dhuafa, Sumsel". Dissertation. Electrical Engineering Study Program, Faculty of Engineering, University of Muhammadiyah Palembang, 2020.
- Kusuma, T.,W., & Sitohang, S. Panel Design Automatic Transfer Switch And Automatic Main Failure With Arduino Based Controller. *Sigma Teknika*, 2(2), 207-223, 2019.
- Majid, A., Eliza., Hardiansyah, R. Automatic Transfer Switch (Ats) Tool As A Solar Cell Hybrid Electrical System in Households. *Journal of Solar Energy*, 2(2), 172-78, 2018.
- Novi Kurniawan, "Electrical Energy Monitoring System And Automatic Transfer Switch (Ats) Controller With Internet Of Things For Solar Power Plants". Thesis. Department of Computer Science, Faculty of Mathematics and Natural Sciences, Semarang State University: Semarang, 2020.
- Putra, R., A. "Design and Build Automatic Transfer Switch (ATS) on PLN Networks and Solar Cells". Thesis. Electrical Engineering Study Program, Department of Electrical Engineering, Padang State Polytechnic: Padang, 2016.
- Sundaru, B., A., S., Pambudi, P., E., & Mujiman. Electrical Power Analysis of 100 Watt Solar Cells as a Backup of Household Electrical Power Equipped with Automatic Transfer Switch (ATS). *Electrical Journal*, 6(1), 11-16, 2019.
- Susanto, E. Automatic transfer switch (a thing). *Journal of Electrical Engineering*, 2018.
- Yakin, K., Rajagukguk, A. Rooftop On Grid System Type Solar Power Plant Design at the Electrical Engineering Laboratory Building, Riau University. *Let's FTEKNIK* 7(2), 1-11, 2020.

BIOGRAPHIES OF AUTHORS



ANTONIUS RAJAGUKGUK was born in Medan, North Sumatra, Indonesia, and joined the University of Riau as a lecturer in 1997. He earned his B.S. Bachelor of Electronic Engineering from Atma Jaya, Catholic University, Jakarta Indonesia, in 1993, and an M.S. degree from the Sepuluh Nopember Institute of Technology (ITS) Surabaya, in 2005. And received a Doctorate degree in Electrical Engineering at the Sepuluh Nopember Institute of Technology (ITS) in 2019. His research interests include the application of power electronics for grid systems, power quality and renewable energy.



KURNIAWAN TRISNA RINALDI was born in Medan October 26, 1999. He became a student at the University of Riau in 2017. He researches on design of MATLAB, automatic transfer switch of solar cell and PLN.