

Design and Implementation Six-Steps Inverter Using Fuzzy Sugeno in Permanent Magnet Synchronous Machines

Reza Sarwo Widagdo*

Electrical Engineering Department
Universitas 17 Agustus 1945 Surabaya
Surabaya, Indonesia
rezaswidagdo@untag-sby.ac.id

Santoso

Electrical Engineering Department
Universitas 17 Agustus 1945 Surabaya
Surabaya, Indonesia
santoso@untag-sby.ac.id

Izzah Aula Wardah

Electrical Engineering Department
Universitas 17 Agustus 1945 Surabaya
Surabaya, Indonesia
iwardah@untag-sby.ac.id

*Corresponding author: Reza Sarwo Widagdo,
rezaswidagdo@untag-sby.ac.id

Abstract— Controlling the speed of the permanent magnet synchronous machines plays an essential role in the industrial process and keeps the permanent magnet synchronous machines running quickly and efficiently. Even if the load changes, the rate speed of the permanent magnet synchronous machines should be adjusted to a constant speed. An excellent permanent magnet synchronous machines speed control system must respond quickly and accurately. However, in practice, rarely find a permanent magnet synchronous machines controlled to achieve a certain speed. This research presents an analysis of fuzzy logic control using seven membership functions for speed control of permanent magnet synchronous machines. Rotor speed control is performed on the rotor voltage by changing the duty cycle value. This voltage change affects the torque of the engine. Adjust the speed by changing the input voltage of the permanent magnet synchronous machines with the six-steps inverter. In the open-loop test (without control), the system cannot reach the desired setting and will only run after input from the throttle. In a closed loop (using fuzzy logic control), the system can achieve the desired setting in 90 seconds even if the setpoint is changed and can move to the setpoint.

Keywords—Fuzzy Logic Control, Permanent Magnet Synchronous Machines, Six-Steps Inverter

I. INTRODUCTION

Permanent magnet synchronous machines (PMSM) have several advantages over brush-type machines. They replace induction machines in many fields due to their simple structure, fast dynamic response, high efficiency, high magnetic flux density in the air gap, and high torque-to-inertia ratio [1]. These machines are often used to work in low and medium power applications for a wide range of applications. They are also used in high-performance electric drives such as robotic systems, space models, and machine tool operations [2], [3]. Permanent magnet synchronous

machines (PMSM) have several electric drives due to their unique characteristics of high power factor, high efficiency, high torque density, and no slip rings. It is becoming a strong candidate for systems with failure rates and good reliability [4], [5]. These features, such as high-speed dynamic performance, developed field-weakening technology, and excellent controllability, make a permanent magnet synchronous machines suitable for traction systems such as electric/hybrid vehicles [6], [7].

Therefore, in recent years, many nonlinear control topologies have been improved for the rate speed control performance of permanent magnet synchronous machines in various uses. The fuzzy logic control (FLC) [8], [9] has different settings, but the design of the fuzzy inference system can improve the speed response. Fuzzy logic control can also reduce overshoot / undershoot at the beginning of response and in a short period. In [10], [11], the authors prove that the most straightforward fuzzy logic controller (FLC) is a nonlinear PI controller whose proportional and integral gains vary with controller input. In addition, since the fuzzy logic system (FLS) incorporates expert knowledge to design Fuzzy logic control and does not need an accurate system model, it provides an efficient tool to embed human intuitive thinking to achieve the desired performances. The six-speed operation of the electric drive is the best solution in that it maximizes DC bus voltage utilization. It provides maximum torque output in areas where magnetic flux is weak. It has attracted significant research interest because it has advantages over conventional space vector pulse width modulation (SVPWM) in the field of magnetic flux weakening [12]–[14]. Since the maximum possible voltage is increased by 10.27%, the constant torque range is extended by 17% by six steps of

operation [15]. This paper uses fuzzy logic control with seven membership functions as a closed-loop system for permanent magnet synchronous machines rate speed control with speed feedback. Moreover, a fuzzy logic control is used to improve the drive system.

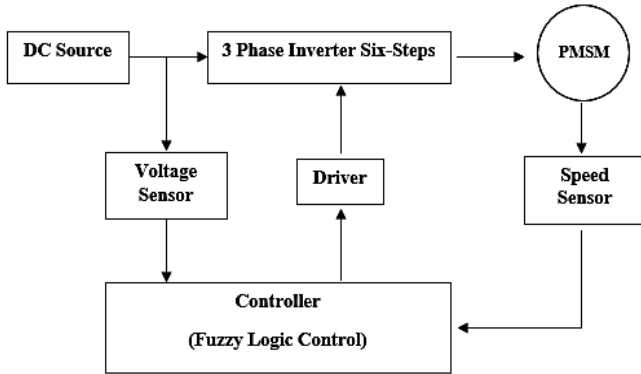

Fig. 1. Block diagram for the simulation model

TABLE 1. Comparative of FLC Techniques used for Permanent Magnet Synchronous Machines Speed

	Advantage	Disadvantage
Fuzzy Logic Control (FLC) [16]	<ul style="list-style-type: none"> • Fast dynamic response • Settling time is short • Excellent efficiency • Reduces the possibility of high-speed sagging due to imminent changes in load 	<ul style="list-style-type: none"> • System is complex • Slight overshoot

The outcome of the proposed method was proved using the simulation of operating conditions. This paper is organized as follows, section 2 discusses about the design and operation of the fuzzy logic control used. Section 3 explain performance simulation. Fuzzy Logic Control (FLC) to drive permanent magnet synchronous machines rate speed control is done using Simulink. Finally, the conclusions are present in section 4.

II. METHODOLOGY

A permanent magnet synchronous machines rate speed control system consists of two control system strategy, as shown in figure 1. The inner loop helps control the inverter gate with electromotive force. The outer circle is designed to use a controller to control the rate speed of the machines.

The inverter gate signal is generated by decoding the speed sensor signal from the rotor. The three-phase output of the inverter applies to the permanent magnet synchronous machines stator windings. The IGBT's switching sequence determines the rotor's position and is recorded by the speed sensor. This modified control using fuzzy logic control can improve the stability and robust performance of the speed control system of permanent magnet synchronous machines. A comparative analysis of fuzzy logic control techniques used for permanent magnet synchronous machines is given in Table 1.

A. Fuzzy Logic Control (FLC)

Fuzzy logic control is an important area of control engineering. Fuzzy logic control is the most successful in undefined method industrial and commercial applications. The fuzzy controller performs three phases of processing: Fuzzification, inference, and defuzzification [17]. From the fuzzy logic control diagram in Figure 2, we can learn that:

1. The fuzzification process is to convert analog quantities into fuzzy inputs.
2. Fuzzy Inference System (FIS) is an application of the rule base generated in the fuzzification process.
3. The defuzzification process is to determine a crisp output value. In defuzzification, all fuzzy output values effectively modify the output membership function.

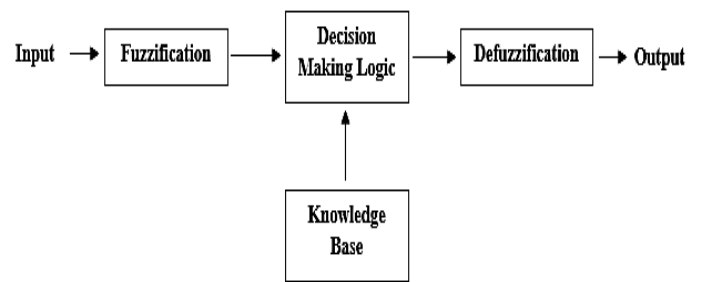

Fig 2. Fuzzy logic control basic structure

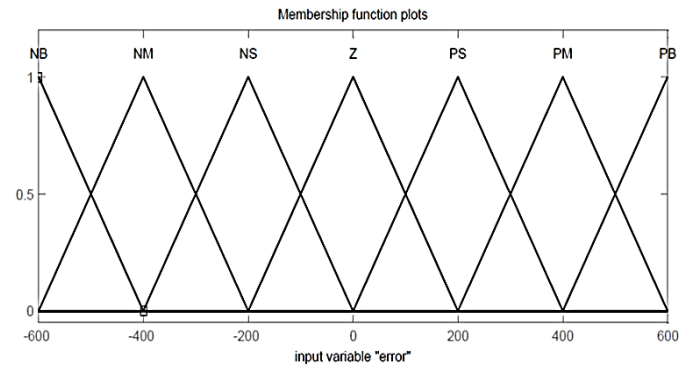

Fig. 3. Design membership function input error

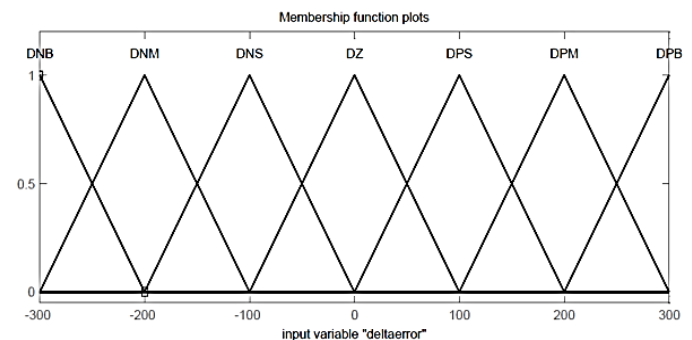

Fig. 4. Design membership function delta error

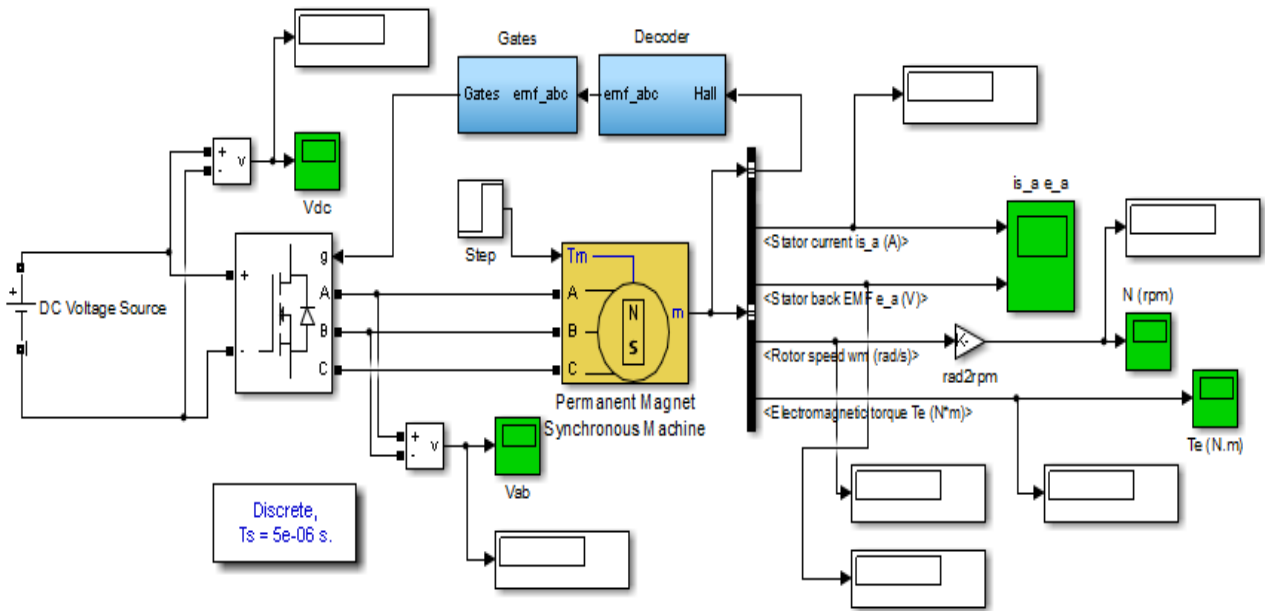

Fig. 5. Permanent magnet synchronous machines open-loop simulation

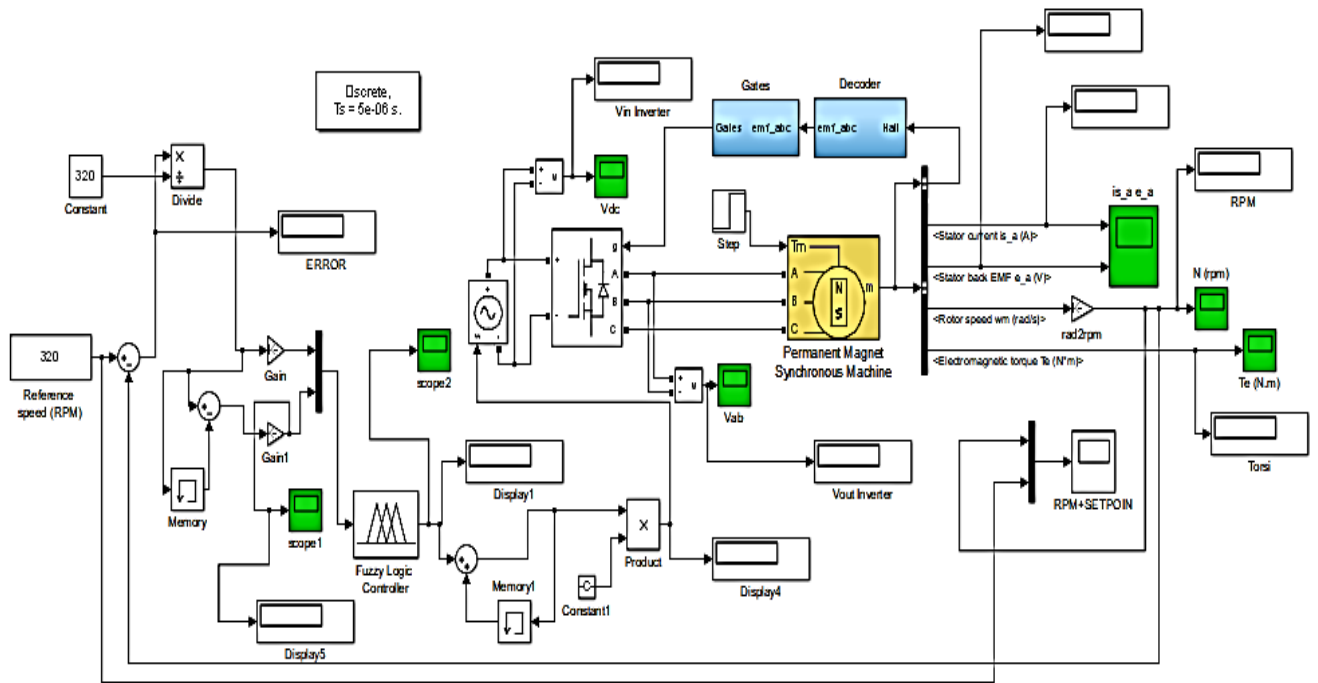

Fig. 6. Permanent magnet synchronous machines rate speed control with fuzzy logic control (FLC)

Initially, we need to determine the membership function of the fuzzy input. This is because the rate speed control system of permanent magnet synchronous machines is a fuzzy system that is used to change the duty cycle according to changes in load. The membership function input must represent error and delta error values. Two inputs were used in this study: error (nominal value - current value) and delta error (current error - previous error). The fuzzy logic consists of two input variables that is error in rate speed and rate of change in pace, and one output variable, as shown in figure 3 and figure 4. The triangular model of membership function has been used for its good performance.

In figure 3, the membership function error is PB represents Positive Big, PM represents Positive Medium, PS represents Positive Small, Z represents Zero, NS represents Negative Small, NM represents Negative Medium, and NB represents Negative Big. Membership function delta error as shown in figure 4, DPB represents Delta Positive Big, DPM represents Delta Positive Medium, DPS represents Delta Positive Small, DZ means Delta Zero, DNS describes Delta Negative Small, NM represents Delta Negative Medium, and DNB represents Delta Negative Big. A rule base consisting of forty-nine rules has been developed on the pre-defined membership functions of two inputs. The rule matrix is shown in Table 2.

TABLE 2. Rule base of Fuzzy Logic Control

e\de	DNB	DNM	DNS	DZ	DPS	DPM	DPB
NB	ONB	ONB	ONB	ONB	ONM	ONS	OZ
NM	ONB	ONB	ONB	ONM	ONS	OZ	OPS
NS	ONB	ONB	ONM	ONS	OZ	OPS	OPM
Z	ONB	ONM	ONS	OZ	OPS	OPM	OPB
PS	ONM	ONS	OZ	OPS	OPM	OPB	OPB
PM	ONS	OZ	OPS	OPM	OPB	OPB	OPB
PB	OZ	OPS	OPM	OPB	OPB	OPB	OPB

Fuzzy rules are at the core of control design, fuzzy logic systems are represented by a series of linguistic descriptions of expert knowledge, and specialist expertise consists of conditional statements such as "if ... then". Fuzzy logic control produces better speed tracking than other control techniques used for permanent magnet synchronous machines rate speed control, but FLC and membership functions rely primarily on expert proficiency [18].

Table 2 shows that $7 \times 7 = 49$ rules are defined based on the signals e and de. To express the working principles of this fuzzy logic control, the following rules are explained:

1. If the input rules of e (k) and de (k) are DNB and NB, respectively, the output result will be ONB;
2. If the input rules of e (k) and de (k) are DZ and NS, respectively, the output result will be ONS;
3. If the input rules of e (k) and de (k) are DZ and Z, respectively, the output result will be OZ.

Figure 5 shows the simulation design for open-loop model of a permanent magnet synchronous machines. Figure 6 describes the simulation model of rate speed control of permanent magnet synchronous machines with fuzzy logic control using Sugeno Model.

III. RESULT AND DISCUSSION

Performance comparison simulation between open-loop and fuzzy logic control for permanent magnet synchronous machines rate speed control is done using Simulink. The six-steps inverter circuit is a machines input voltage and speed as a feedback controller.

A. Open-Loop Condition of Permanent Magnet Synchronous Machines

An uncontrolled condition or commonly known as the open-loop test, aims to determine the characteristics of the permanent magnet synchronous machines. The duty cycle value of the pulse generator used by the six-steps inverter is adjusted so that the speed follows the standard speed reference of 320 rpm. With this open-loop test method, the permanent magnet synchronous machines operated at a reference speed without load and a controller. The response result from this condition becomes the initial parameter for designing a suitable controller.

B. Fuzzy Logic Control (FLC) Condition of Permanent Magnet Synchronous Machines

In the proposed model, the Fuzzy Logic Control (FLC) controls the working of the speed controller. The inputs provided to the fuzzy logic controller (FLC) are: (1) The error in speed, i.e., the difference between the desired and the actual speed of the permanent magnet synchronous machines. (2) The rate of change of the error in speed the output of the fuzzy logic control (FLC) is the setpoints for the speed controller. With this fuzzy logic control (FLC) test method, the permanent magnet synchronous machines operated at a reference speed with the controller. The setpoint for the speed controller is the reference for the outer loop of the six-steps inverter.

C. The Results of the Comparison Between Open-Loop using Fuzzy Logic Control

The simulation results can be seen in Figure 7 in the open loop condition with a reference speed value of 320 rpm, the rise time value obtained is 0.09 seconds, with a settling time value of 0.45 seconds, and in steady conditions the resulting rotational speed is 315 rpm with a percentage of error 1.6%. These parameters will be used to design a fuzzy logic control. In the simulation using fuzzy logic control with the same speed reference value of 320 rpm, the rise time value is 0.8 second, the settling time value occurs at 3.5 seconds with the resulting rotational speed at steady state conditions of 320 .1 rpm with a percentage of error to the reference value of 0.03%.

In the comparison of the inrush current shown in Figure 8, the use of the control method with fuzzy logic control can reduce the inrush current value by 57% of the value in the open loop condition. It is observed that the stator currents are quasi-sinusoidal in shape. The stator current waveforms of PMSM at open-loop conditions are shown in figure 9. In addition to inrush currents, it turns out that using this fuzzy logic control (FLC) control method can actually reduce the amount of current at steady state produced on permanent magnet synchronous machines with a percentage reduction of 25%.

In Figure 10, you can see that the line-to-line output voltage of the six-steps inverter is not a sinusoidal waveform. This is due to the switching process of the six-steps inverter that produces the harmonics. A filter is needed to reduce the harmonics so that the output voltage produces a good sinusoidal waveform. Since the permanent magnet synchronous machines uses six-levels of rectification, the output voltage waveform of the six-steps inverter also differs by 120° for each phase.

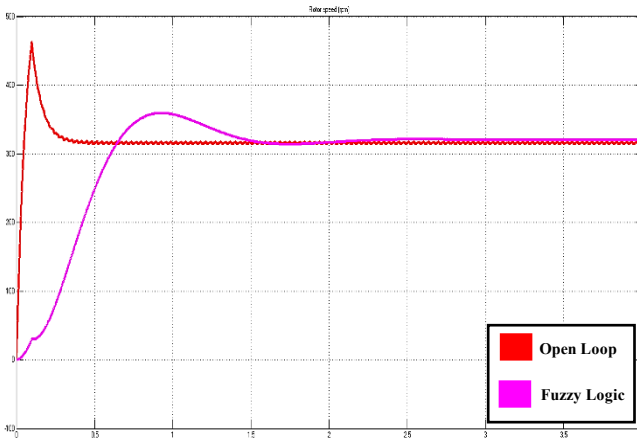

Fig. 7. Speed response open-loop vs fuzzy logic control

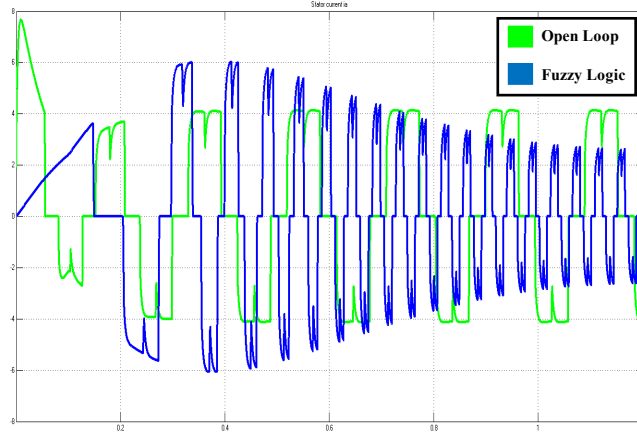

Fig. 8. Inrush current open-loop vs fuzzy logic control

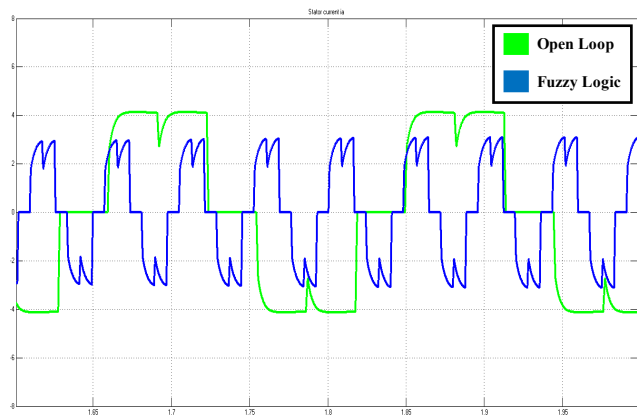

Fig. 9. Stator current open-loop vs fuzzy logic control

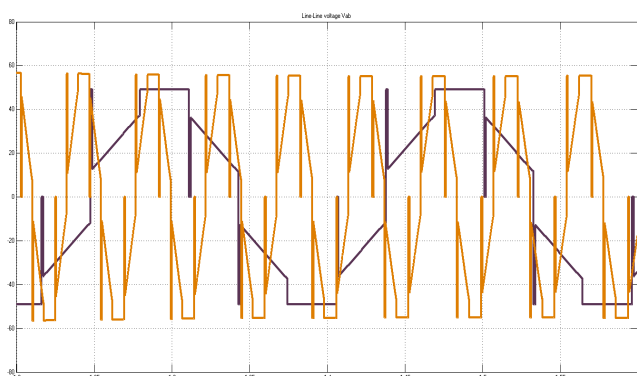

Fig. 10. Six-step inverter output voltage open-loop vs fuzzy logic control

TABLE 3. Characteristics of speed response

Condition	Rise Time (T_R)	Settling Time (T_S)	Steady State Speed	Overshoot Percentage
Open-Loop	0.09 s	0.45 s	315 rpm	46.03%
FLC	0.8 s	3.5 s	320.1 rpm	12%

TABLE 4. Result of using control

Condition	Starting Current	Steady State Current	Electromagnetic Torque	Stator Back EMF
Open-loop	7.7 A	4.15 A	3,155 Nm	12.7 V
FLC	6.05 A	3.05 A	3,5 Nm	19.2 V

Table 3 shows characteristics of the comparison of two conditions simulation results such as rise time (T_R), settling time (T_S), and overshoot percentage. The rise time and settling time of the open-loop condition are less than the fuzzy logic control. The overshoot percentage of fuzzy logic control is better than the open-loop condition. The characteristics show that the open-loop state of the permanent magnet synchronous machines rate speed control is better using fuzzy logic control because it can reduce overshoot as happened to the open-loop condition. But consequently, the rise time in fuzzy logic control is longer than the rise time in the open-loop state. The speed demand is provided by the accelerator on the permanent magnet synchronous machines.

It is explained in table 4 that the use of fuzzy logic control is very profitable. When viewed in terms of the starting current and current at steady state conditions, fuzzy logic control can reduce the current value compared to without control. In addition, there is an increase in electromagnetic torque by using fuzzy logic. Fuzzy logic control can learn faster against sudden change conditions compared to an open-loop state. When there is a change in the setpoint, or a system has a varying setpoint like the speed control, fuzzy logic control design can be used at various set points, and the output response remains constant. The controller may reduce the transient at the starting point and make it stable in a short period.

IV. CONCLUSION

Based on the analysis of the data that has been obtained from the simulations that have been carried out with the designs made, it can be concluded that: (1) When the system operates in an open-loop simulation, the rotor speed value can't reach the desired set point value, and it will continue to increase until the maximum speed value. Fuzzy logic control (FLC) is needed so that the rotor rotation can reach the set point value. (2) The control can achieve the given set point value even though the set point value is changed, and when the system is disturbed, the control can return to the set point value. (3) This characteristic shows that the closed-loop state of permanent magnet synchronous machines rate speed control is excellent when using fuzzy logic control because it can reduce overshoot as it does in the open-loop form.

However, as a result, the rise time of fuzzy logic control is longer than the rise time of the open loop state.

REFERENCES

- [1] Fan, S., & Tong, C. Model predictive current control method for PMSM drives based on an improved prediction model. *Journal of Power Electronics*, 20(6), 1456-1466, 2020.
- [2] Z. Deng and X. Nian, "Robust control of permanent magnet synchronous motors," in *IEEE/CAA Journal of Automatica Sinica*, vol. 2, no. 2, pp. 143-150, 10 April 2015.
- [3] Ma, Y., & Li, Y. Active disturbance compensation is based on robust control for the permanent magnet synchronous motor speed regulation system. *Applied Sciences*, 10(2), 709, 2020.
- [4] S. Driss, S. Farhangi and M. R. Nikzad, "Low switching frequency model predictive control of PMSM drives for traction applications," 2018 9th Annual Power Electronics, Drives Systems and Technologies Conference (PEDSTC), pp. 300-305, 2018.
- [5] A. Ayad, P. Karamanakos, R. Kennel and J. Rodríguez, "Direct model predictive control of bidirectional quasi-Z-source inverters fed PMSM drives," 2017 11th IEEE International Conference on Compatibility, Power Electronics and Power Engineering (CPE-POWERING), pp. 671-676, 2017.
- [6] X. Sun et al., "MPTC for PMSMs of EVs With Multi-Motor Driven System Considering Optimal Energy Allocation," in *IEEE Transactions on Magnetics*, vol. 55, no. 7, pp. 1-6, July 2019.
- [7] X. Yuan, S. Zhang, and C. Zhang, "Enhanced Robust Deadbeat Predictive Current Control for PMSM Drives," in *IEEE Access*, vol. 7, pp. 148218-148230, 2019.
- [8] De Soricellis, M., Da Ru, D., & Bolognani, S. A robust current control based on proportional-integral observers for permanent magnet synchronous machines. *IEEE Transactions on Industry Applications*, 54(2), 1437-1447, 2017.
- [9] M. Abdelrahman, C. Hackl, R. Kennel, and J. Rodriguez, "Sensorless Predictive Speed Control of Permanent-Magnet Synchronous Generators in Wind Turbine Applications," *PCIM Europe 2019; International Exhibition and Conference for Power Electronics, Intelligent Motion, Renewable Energy and Energy Management*, pp. 1-8, 2019.
- [10] Bansal, U. K., & Narvey, R. Speed control of DC motor using fuzzy PID controller. *Advance in Electronic and Electric Engineering*, 3(9), 1209-1220, 2013.
- [11] P. K. Khanke and S. D. Jain, "Comparative analysis of speed control of BLDC motor using PI, simple FLC and Fuzzy - PI controller," 2015 International Conference on Energy Systems and Applications, pp. 296-301, 2015.
- [12] X. Sun, Z. Shi, G. Lei, Y. Guo, and J. Zhu, "Analysis and Design Optimization of a Permanent Magnet Synchronous Motor for a Campus Patrol Electric Vehicle," in *IEEE Transactions on Vehicular Technology*, vol. 68, no. 11, pp. 10535-10544, Nov. 2019.
- [13] S. Zhao, X. Huang, Y. Fang, and H. Zhang, "DC-Link-Fluctuation-Resistant Predictive Torque Control for Railway Traction Permanent Magnet Synchronous Motor in the Six-Step Operation," in *IEEE Transactions on Power Electronics*, vol. 35, no. 10, pp. 10982-10993, Oct. 2020.
- [14] F. Momen, K. Rahman and Y. Son, "Electrical Propulsion System Design of Chevrolet Bolt Battery Electric Vehicle," in *IEEE Transactions on Industry Applications*, vol. 55, no. 1, pp. 376-384, Jan.-Feb. 2019.
- [15] Y.-C. Kwon, S. Kim, and S. -K. Sul, "Six-Step Operation of PMSM With Instantaneous Current Control," in *IEEE Transactions on Industry Applications*, vol. 50, no. 4, pp. 2614-2625, July-Aug. 2014.
- [16] Liu, X., & Zhang, Q. Robust current predictive control-based equivalent input disturbance approach for PMSM drive. *Electronics*, 8(9), 1034, 2019.
- [17] Liu, J., & Wang, X. *Advanced sliding mode control for mechanical systems* (pp. 31-35). Berlin: Springer, 2012.
- [18] J. Ma, J. Zhao, J. Sun and C. Yan, "A novel PMSM speed control scheme based on sliding-mode and fuzzy disturbance observer," *IECON 2017 - 43rd Annual Conference of the IEEE Industrial Electronics Society*, pp. 1704-1710, 2017.

BIOGRAPHIES OF AUTHORS



REZA SARWO WIDAGDO is a lecturer in Electrical Engineering Department at the Universitas 17 Agustus 1945 Surabaya, Indonesia. He received his B.A.Sc. in Electrical Industrial Engineering from *Politeknik Elektronika Negeri Surabaya, Indonesia* in 2019, M.Eng. in Electrical Engineering from *Institut Teknologi Sepuluh Nopember, Surabaya, Indonesia* in 2021, and Doctoral student in Electrical Engineering at *Institut Teknologi Sepuluh Nopember, Surabaya, Indonesia*. His research interests include the field of power electronics, motor drives, and high voltage engineering.



SANTOSO is a lecturer in Electrical Engineering Department at Universitas 17 Agustus 1945 Surabaya, Indonesia. He received his B.Eng. degree in Electronic Engineering from National Institute of Technology in 1997, M.Eng. in Electronic Engineering from Sepuluh Nopember Institute of Technology in 2012, and Doctoral student in Electronic Engineering at Sepuluh Nopember Institute of Technology. His research interests include the Biomedical Engineering, Artificial Intelligence, Robotic.



IZZAH AULA WARDAH is a lecturer in Electrical Engineering Department at Universitas 17 Agustus 1945 (Untag), Surabaya, Indonesia. She received her B.A.Sc. degree in Electronics Engineering from *Electronic Engineering Polytechnic Institute of Surabaya* in 2015 and *M.Eng.Sc degree from the University of New South Wales, Australia* in 2020. Her expertise includes renewable energy, low energy building, PV, and sustainable systems.